

Product Information Dispensing Cell DC-CNC

Compact and flexible – the new dimension for dynamic sealing, encapsulating and bonding



Two DC-CNC with rotary index table ▷

DC-CNC with rotary index table ▷▷

DC-CNC with vertical lift door and OP010 in swivel arm ▷

DC-CNC with retractable rinsing system ▷▷



Your advantages

» Compact design with integrated

- Control cabinet
- 2K-material conditioning equipment
- Safety housing

» High flexibility

- Can be combined with all available RAMPF mixing and dispensing systems
- Manual operator loading or automatic robot loading

» Control

- Siemens Sinumerik NC-controls with teach panel
- Fast and easy programming of different parts by recipe management

» Highspeed 3-axis linear robot

- Max. acceleration 10 m/s²
- Maintenance-free-ball screw spindles

» Integrated process monitoring

Permanent control of pressures, tank level and drives



Dispensing Cell DC-CNC

Product details

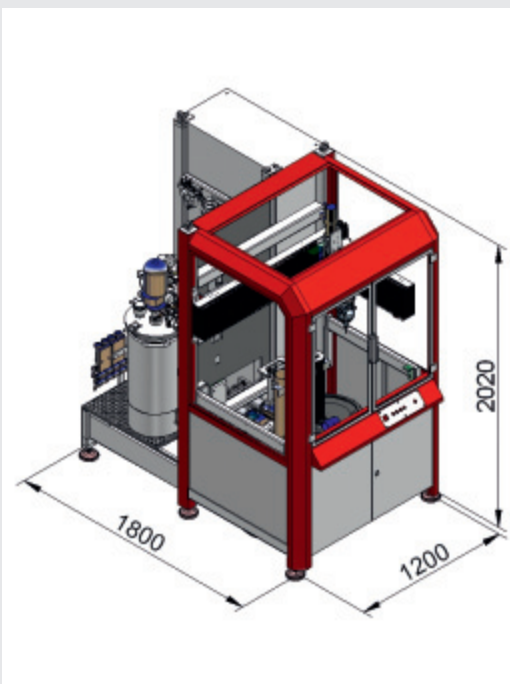

The DC-CNC is the compact solution requiring minimum space. It combines flexibility and dynamics for the 2D- or 3D-dispensing of sealants, adhesives and resins. State of the art control technology joins dispensing technology with the precise movement of the linear robot. The modular control design allows fast and simple integration into any production system.



Technical Data (subject to change)

Flow rate, mixing ratio, number of components, viscosity	Depending on installed mixing system
Max. travel speed	X, Y = 60 m/min, Z = 24 m/min
Max. acceleration	10 m/s ²
Repeatability	< 0.10 mm (ISO 9283)
Controls	Siemens Sinumerik 810D/840D
Dispensing programs	99
Electrical supply	400 V / 16–32A / 50Hz (60 Hz)
Power consumption	5.5–12 kw
Compressed air supply	> 5 bar at max. flow rate 800 l/min.
Compressed air consumption	5–20 l/min.
Weight	Approx. 850 kg
Work area	X, Y, Z, = 800, 400, 200 mm

Options (more upon request)

- » HP rinse recycling system or HP water rinsing system
- » Nucleation controller for air load controls of gasket materials
- » Material recirculation system and temperature controller
- » Automatic thin-layer degassing system for bubble-free potting
- » Various automation equipment available
- » Individual process monitoring and visualization
- » 10" or 12" colour display with integrated PC, interfacing to customer's PPS
- » Integrated shot-weight scale, nozzle check station, nozzle cleaning station

